

41C30 PROBE SHOWN
OTHER PROBES AVAILABLE

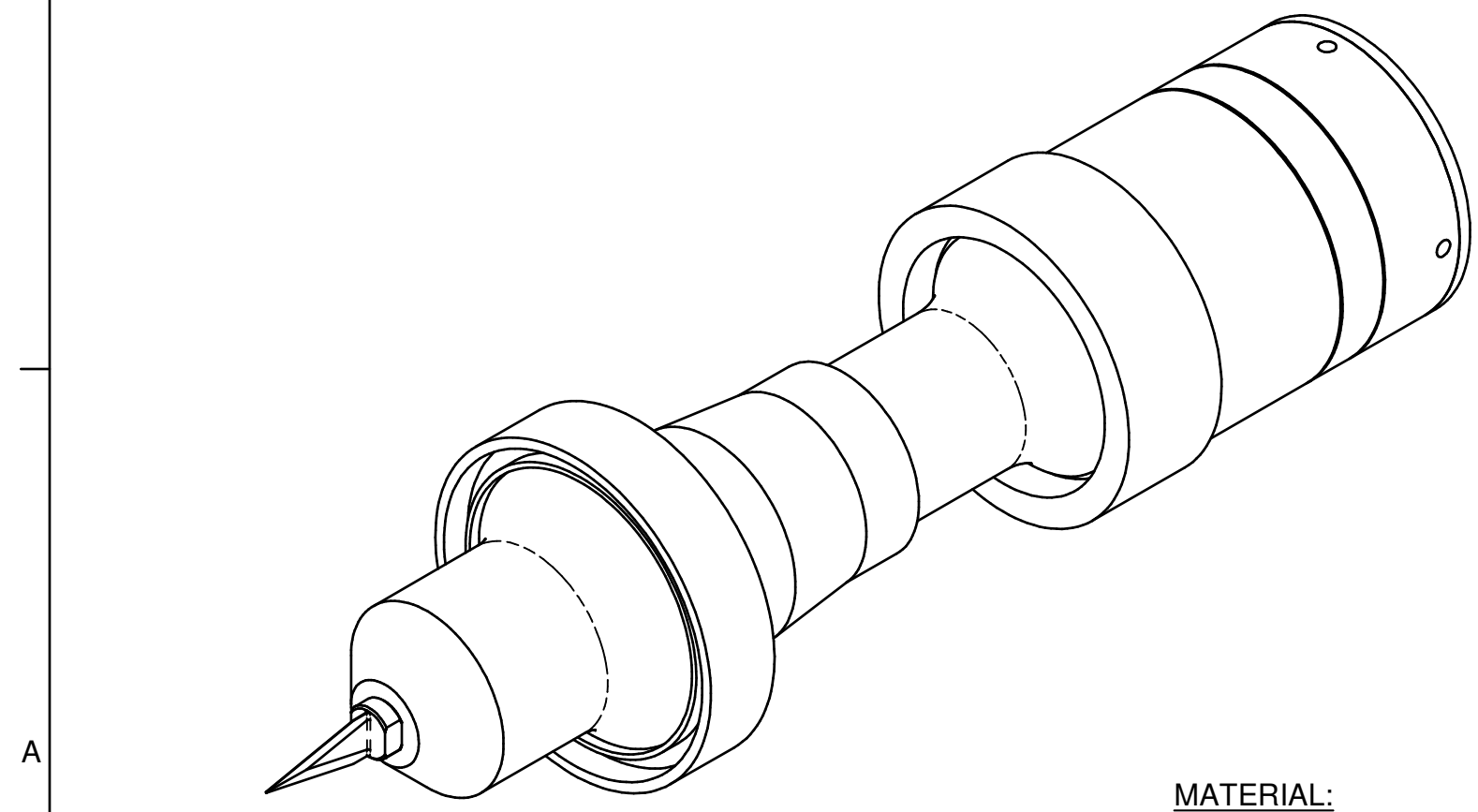

NOTE:
HORN AND TRANSDUCER DIMENSIONS
ARE FOR REFERENCE AND MAY VARY
DEPENDING UPON THE SPECIFIC HORN,
KNIFE TIP AND TRANSDUCER CHOSEN.

CONSULT DUKANE FOR EXACT DIMENSIONS
BASED ON MODEL NUMBERS ORDERED.

MATERIAL:		FINISH:		UNLESS OTHERWISE SPECIFIED: DIMENSIONS ARE IN INCHES		2 PLACE DECIMAL: ± .010		3 PLACE DECIMAL: ± .005		FRACTIONS: ± 1/64		ANGLES: ± .5°	
CAD GENERATED DO NOT MANUALLY REVISE			DUKANE	LAYOUT DRAWING 20KHZ KNIFE STACK WITH RESONANT HORN				SCALE: FULL	ECN:	DATE: 10/27/2008			
	NEXT ASSY	FIRST USED						DRAWN kostermj	APPROVED WJ	NO. knifestack		SHEET 1 OF 1	
SHEET SIZE: C		APPLICATION		ST. CHARLES, ILLINOIS 60174		CHECKED WJ	ENGINEER						