

Emergency Stop and Cycle Activation Interface For J902 of a DPC II and DPC II+ Welding Systems

DPC II and DPC II+ welding systems that are equipped with the optional pneumatic press feature, are also equipped with the J902 Base Plate / Abort interface. This connector provides an interface that allows automation to control cycle activation and cycle termination during an emergency stop condition. This document will provide guidelines that will help you interface automation to a DPC welding system per Dukane Corporation's requirements. Information within this document is intended to supplement the information in the DPC II manual (Dukane part # 403-558) and DPC II+ manual (Dukane part # 403-551).

Warning: Compliance with all related safety requirements of the safety regulatory agencies governing the geographic location where the Dukane equipment will be operated is required before the Dukane equipment is operated.

Application Note Topics:

- The J902 Pin assignments
- The 200-1124 Interface Cable
- The 200-1293 Emergency Stop Bypass Plug
- System Input Signal Descriptions
- System Input Interface Examples

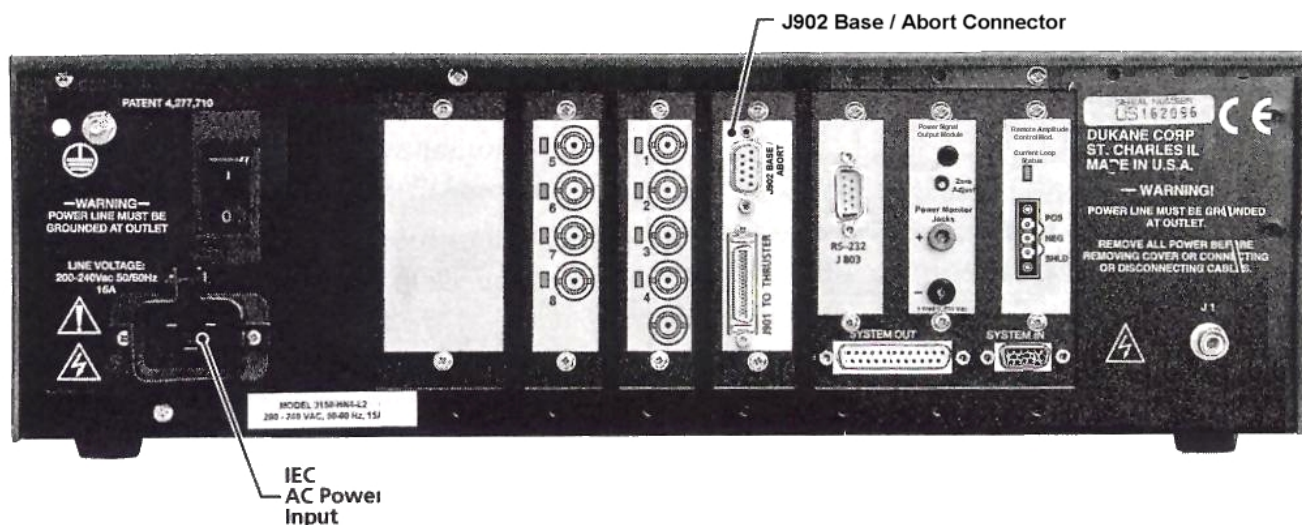

Dukane Corporation
2900 Dukane Drive Saint Charles, IL 60174 USA
Phone (630) 797-4900 FAX (630) 797-4949
<http://www.dukane.com/us>

J902 Base Interface Connector

The J902 Base Interface connector is an optional feature on all DPC II and DPC II+ welding systems that are equipped to control a Dukane pneumatic press. It provides automation with an interface to initiate and terminate the DPC welding system cycle. All DPC II and DPC II+ welding systems equipped with J902 must utilize the Emergency Stop feature of the J902 connector for proper operation of the DPC welding system.

*Note: Pin numbers indicating an “ * “ are only available on DPC II+ welding systems.*

| Pin Number | DPC Signal Name | DPC Signal Type |
|------------|----------------------------|------------------------------|
| 1 * | Manual Activation Switch 1 | Input |
| 2 * | Manual Activation Switch 2 | Input |
| 3 | Emergency Stop | Input |
| 4 * | Emergency Stop Sense | Input |
| 5 | Ground | DPC Supply Ground |
| 6 | No Connections | N/C |
| 7 | Ground | Ground Pin for Input Signals |
| 8 | Automation Start | Input |
| 9 | +22 VDC | Power Supply |

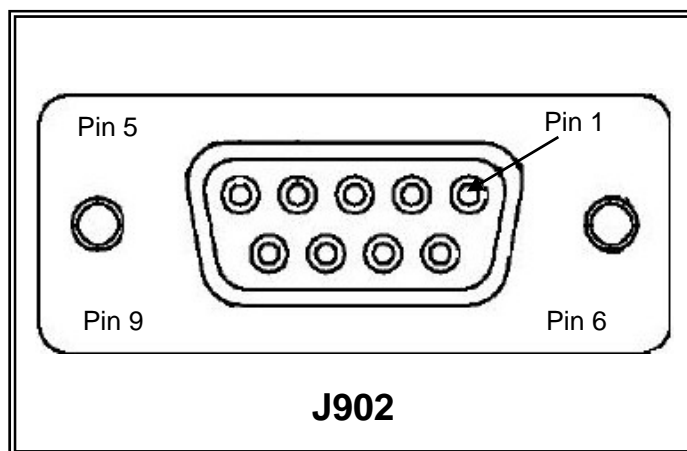

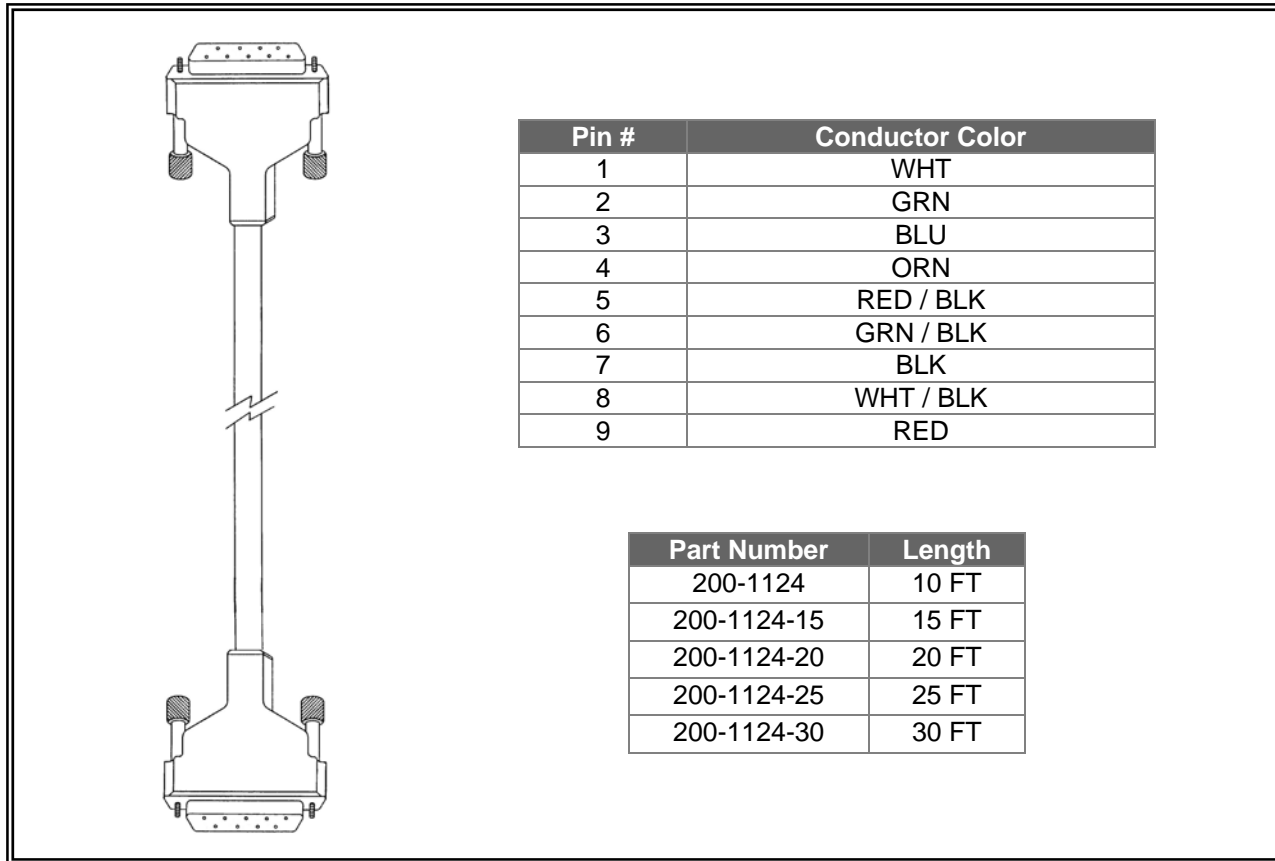

The 200-1293 emergency stop bypass plug is designed to bypass the emergency stop feature of the J902 connector. Use of the 200-1293 shorting plug is restricted to DPC II and DPC II+ welding systems that do not require the use of the DPC Emergency Stop feature to comply with all applicable safety requirements as directed by compliance agencies which include but are not limited to CE, OSHA, CSA, and UL.

Warning: The 200-1293 Emergency Stop bypass plug should not be used on systems that either do not comply with applicable safety regulations when the plug is in use or on systems that can expose the operator to a safety hazard related to the operation of Dukane equipment.

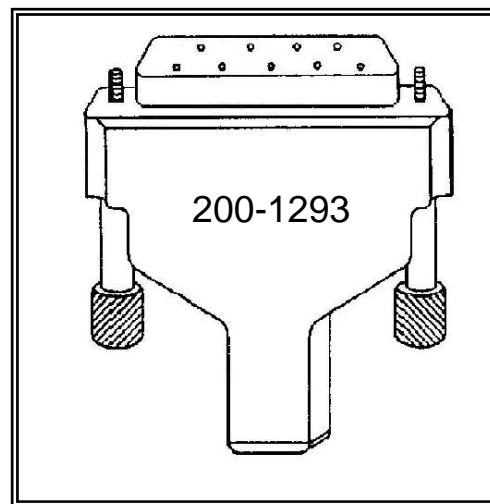

J902 System Input Signal Descriptions:

| | |
|--------------------|---|
| +22 VDC - | (J902 pin 3) This system power supply provides the voltage required for the Dukane pneumatic press and other safety related features of the DPC welding system. It is connected to a set of normally closed contacts within the emergency stop switch. |
| Emergency Stop - | (J902 pin 9) This system input receives the DPC +22VDC power supply signal that is returning from a set of normally closed contacts of the emergency stop switch. This signal functions as a power supply for the Dukane pneumatic press as well as other features related to safety of the DPC welding system. Activation of the emergency stop switch will open the switch contacts and remove the +22VDC power supply from this pin. This switch should be activated simultaneously with the E-Stop Sense system input (E-Stop Sense system input is only required for DPC II+ welding systems). |
| E-Stop Sense - | (J902 pin 4) This system input is activated by a set of normally open contacts within the emergency stop switch that closes during an emergency stop switch activation. This input functions as an emergency stop status signal for the DPC II+ welding system. This switch should be activated simultaneously with the Emergency Stop system input. (This feature is only available on DPC II+ welding systems). |
| Ground - | (J902 pin 5 and pin 7) This DPC power supply ground connects to a normally open set of contacts within the emergency stop switch. It is used for the activation of the E-Stop Sense, Safety Switch, and Automation system inputs. (E-Stop Sense and Safety Switch system inputs are only available on DPC II+ welding systems). |
| Safety Switch #1 - | (J902 pin 1) This system input is one of two system inputs that interface with palm activation switches. It is activated by a dry contact switch closure from the palm switch when utilizing the "Manual" initiate feature of the DPC II+ welding system. Activation of this input must occur within 100mS of the activation of Safety Switch #2 and must be maintained until the trigger switch of the pneumatic press is activated. Please refer to the Initiate Mode section of the DPC II+ manual for details on the activation and use of the "Manual" initiate mode. (This feature is only available on DPC II+ welding systems). |
| Safety Switch #2 - | (J902 pin 2) This system input is one of two system inputs that interface with palm activation switches. It is activated by a dry contact switch closure from the palm switch when utilizing the manual activation feature of the DPC II+ welding system. Activation of this input must occur within 100mS of the activation of Safety Switch #1 and must be maintained until the trigger switch of the pneumatic press is activated. Please refer to the Initiate Mode section of the DPC II+ manual for details on the activation and use of the "Manual" initiate mode. (This feature is only available on DPC II+ welding systems). |
| Automation Input - | (J902 pin 8) This system input signal activates a DPC welding cycle when an automated device is being used to initiate the welding cycle. It is activated by an external dry contact closure to the DPC ground on J902 pin 7. <i>DPC II+ welding systems</i> – Requires the configuration of the initiate mode of the DPC II+ software to the "Auto" mode. The minimum duration for the activation of this input is 100 mS. The maximum duration of this input is determined by the duration of the weld cycle. This input should be deactivated before the end of the weld cycle to avoid an error condition (Associated Error: # E06 Auto Active at Cycle Start). Please refer to the Initiate Mode section of the DPC II+ manual for details on the activation and use of the "Auto" initiate mode. <i>DPC II welding systems</i> – Ultrasound will remain active for the duration of the contact closure. |

DPC II + System Activation Examples:

Warning: The diagram below is a simplified example that demonstrates the basic requirements to interface with a DPC II + welding system. Compliance with all related safety requirements of the safety regulatory agencies governing the geographic location where the Dukane equipment will be operated is required before the Dukane equipment is operated.

Note: DPC II welding systems are not equipped with the Safety Switch feature on pins 1 and 2 of the J902 connector.

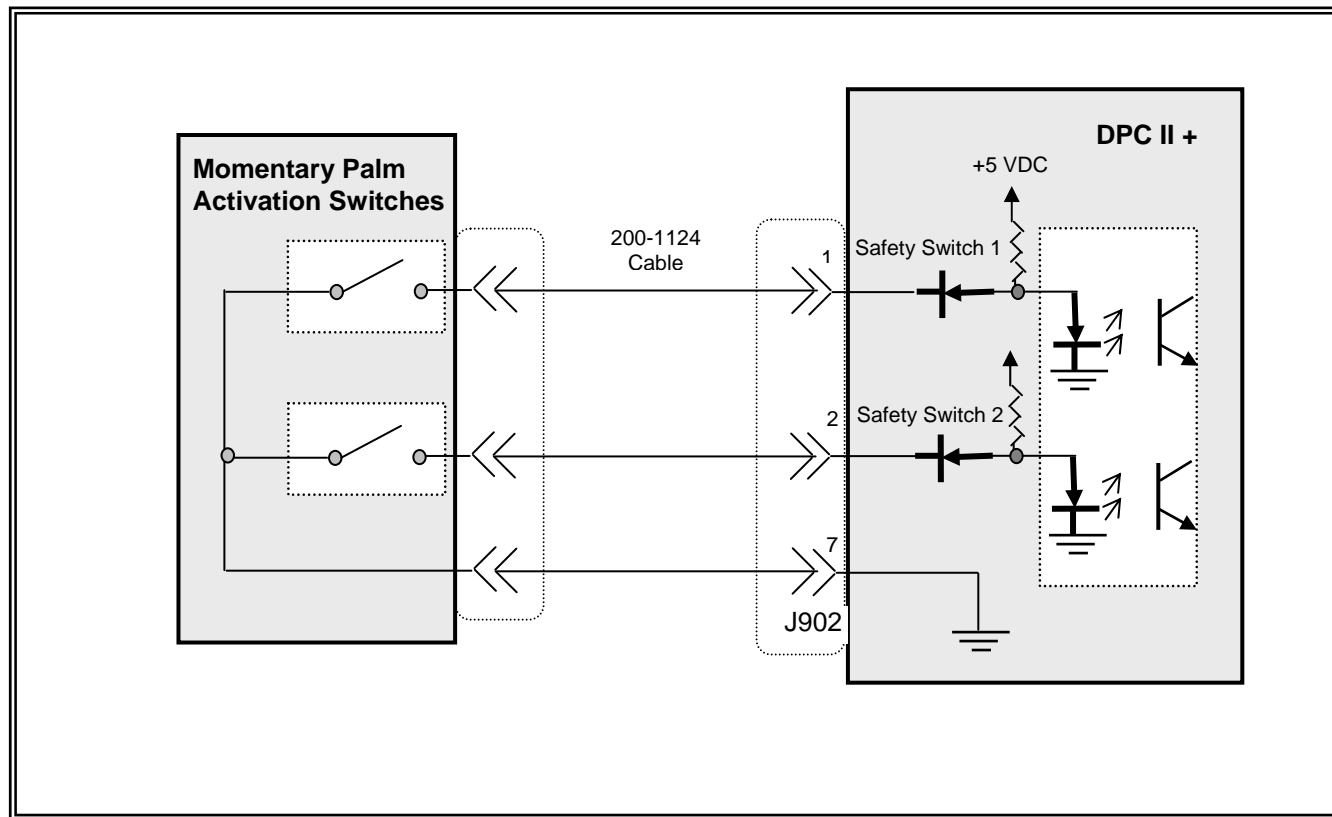

DPC II and DPC II + System Activation Examples (Continued):

Warning: The diagram below is a simplified example that demonstrates the basic requirements to interface with a DPC II and DPC II + welding systems. Compliance with all related safety requirements of the safety regulatory agencies governing the geographic location where the Dukane equipment will be operated is required before the Dukane equipment is operated.

Note: The System In connector of the DPC II and DPC II + welding system is also equipped with an automation activation interface. Please refer to applicable DPC manual for further information on the use of the System In connector.

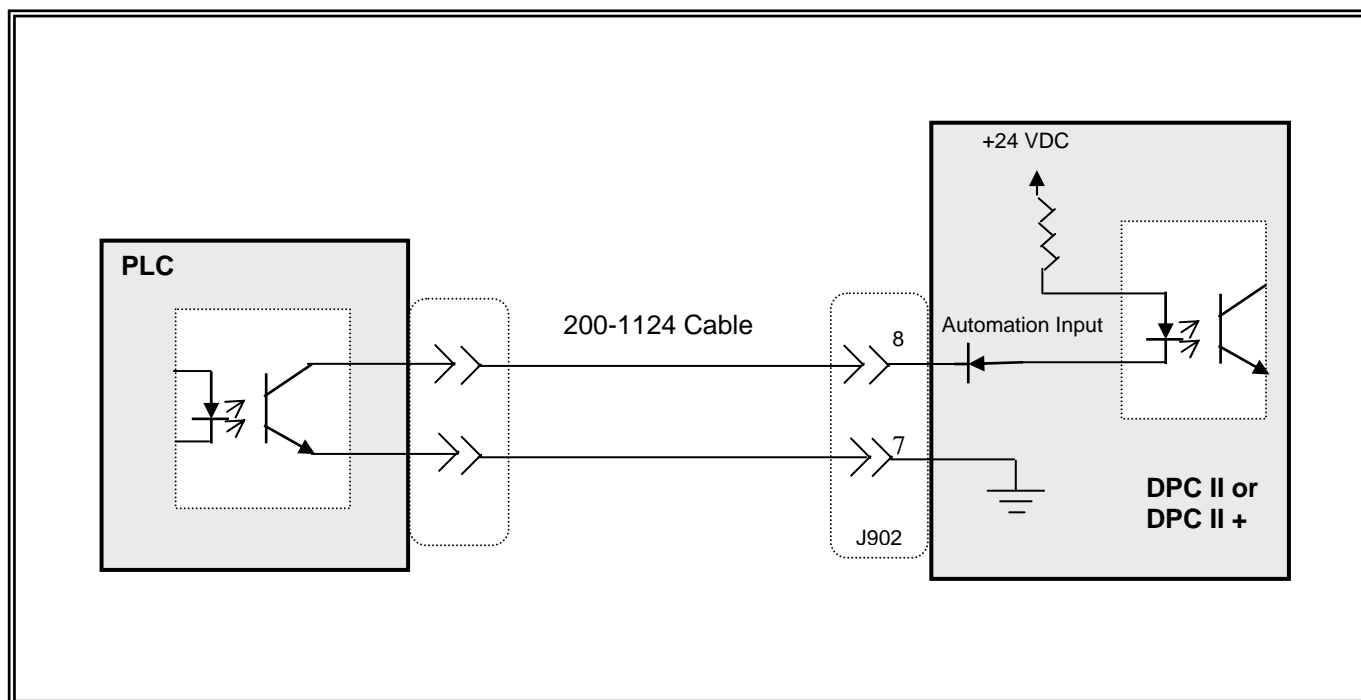

J902 Automation Activation Interface Example

DPC II / DPC II + System Activation Examples (Continued):

Warning: The diagram below is a simplified example that demonstrates the basic requirements to interface with a DPC II and DPC II + welding systems. Compliance with all related safety requirements of the safety regulatory agencies governing the geographic location where the Dukane equipment will be operated is required before the Dukane equipment is operated.

Note: The System In connector of the DPC II and DPC II + welding system is also equipped with an automation activation interface. Please refer to applicable DPC manual for further information on the use of the System In connector.

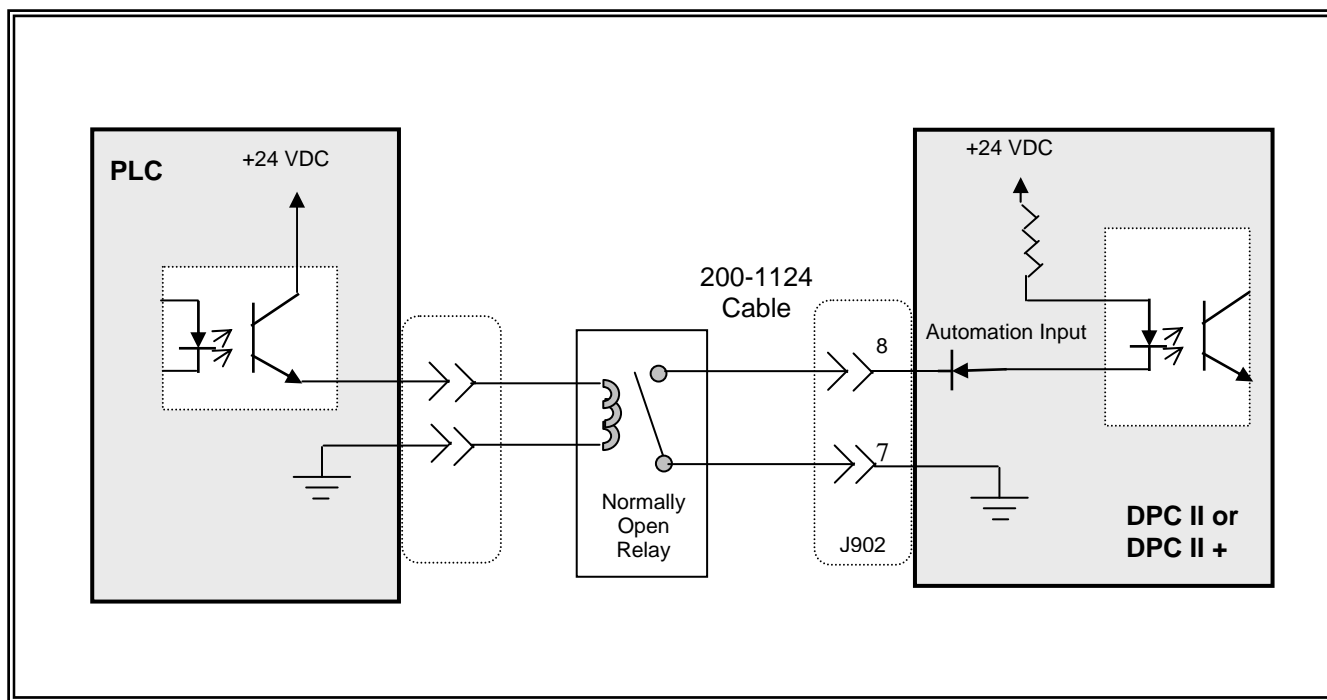

J902 Automation Activation Interface Example

DPC II and DPC II + Emergency Stop Examples:

Warning: The diagram below is a simplified example that demonstrates the basic requirements to interface with a DPC II and DPC II + welding systems. Compliance with all related safety requirements of the safety regulatory agencies governing the geographic location where the Dukane equipment will be operated is required before the Dukane equipment is operated.

Note: DPC II welding systems are not equipped with the E-Stop Sense feature on pin 4 of the J902 connector.

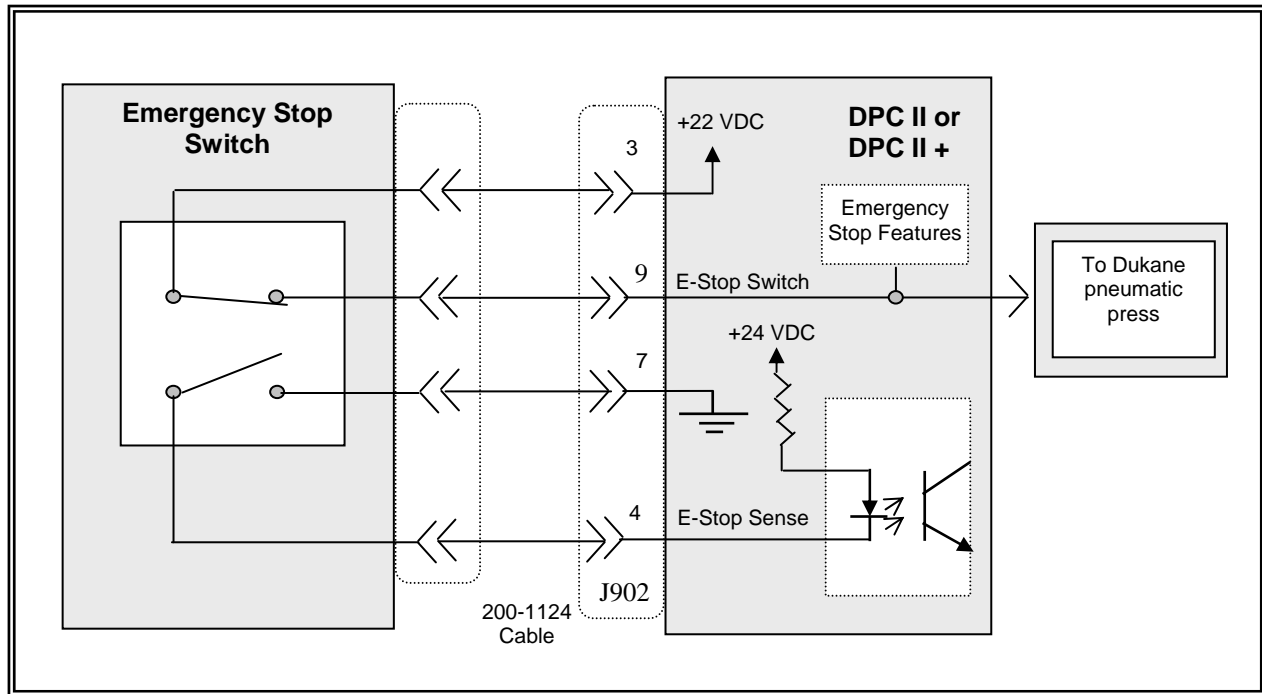

J902 Emergency Stop Interface Example